

The Effect Of Perceived Diversity Climate On General Satisfaction Of University Students

İlhan KAÇIRE

Asst. Prof., Dicle University, Ziya Gökalp Faculty Of Education

Educational Sciences Department, Diyarbakır

Email: il.ka.1010@hotmail.com

Mehmet KURTULMUŞ

Ph.D., Dicle University, Ziya Gökalp Faculty Of Education

Educational Sciences Department, Diyarbakır

Hüseyin KARABIYIK

Res.Assist, Dicle University, Ziya Gökalp Faculty Of Education

Educational Sciences Department, Diyarbakır

Doi:10.5296/ijld.v5i2.7425 URL: <http://dx.doi.org/10.5296/ijld.v5i2.7425>

Abstract

The aim of this research is to examine the effect of perceived diversity climate on general satisfaction of university students. The research was done with relational survey model. 273 students having education in Dicle University Ziya Gökalp Faculty of Education and Faculty of Theology constituted the working group. Research data were collected with 'diversity climate' and 'general satisfaction' scales. Data were analyzed by setting up structural equation modeling. It has been seen that goodness of fit indexes of set model are among the range standart value. In the research, It has been determined that perceived diversity climate has effected the general satisfactions of university students positively and significantly. It is also confirmed that perceived diversity climate has explained the general satisfaction of university students in a significant level. In accordance with these results it can be said that it is important for the universities aiming to increase the general satisfaction of students to produce qualified policies related to student diversity.

Keywords: Diversity, students' satisfaction, higher education

Introduction

In the 21st century it is seen that both individual and cultural diversity make themselves more apparent in organizations. Diversity's coming into focus day by day makes it obligatory to take the diversity into account. In fact, diversity can be seen as a reality (Van Vuuren, Westhuizen ve Walt, 2012: 155) that should be taken into consideration. Diversity is one of the factors that can source many problems or benefits for organizations. Diversity may be both a strategic asset or a great obstacle for organisations. Organisations' obtaining competitive advantages, its being more reformist, enhancing the general satisfaction (G.S) (Hubbard, 2004: 40), enabling the increase productivity of workers, playing an important role in solving problem (Knouse, 2008; Cox ve Blake, 1991) can be listed as potential benefits that diversity can ensure for the organisation. However, increase of conflict, othering, exclusion, discrimination, loss of productivity, increase of stress and unqualified in-house communication can be listed as the problems that diversity can cause in organization. (CIPD Change Agenda, 2005; Barutçugil, 2011).

One of the places where diversity is seen intensely or diversity evokes itself are universities. Universities are the settings where cultures, sexes, life styles, life perspectives, thoughts, ethnic origins separate and differentiate from each other. On the one hand, the presence of graduate students, and on the other hand the presence of new attendants reveals that diversity is a phenomenon offering continuity. Therefore, universities' providing the continuation of the related phenomenon healthfully inside the campus by introducing inclusive policies and performing managerial practices is an important situation.

In related literature, just one study has been found in institutional level intended for diversity climate (D.C) in Turkey. Besides, in universities where diversity standing out at the highest level, there are no researches done about related field. Whereas, it is possible to run across different researches in abroad about the subject in both universities and management organisations. It is possible to say that the researches done about diversity climate will contribute to the related field in Turkey. In this context, it is thought that the investigation of perceived diversity climate's effect on students' satisfaction is very important. Within this scope, at first the knowledge about diversity climate and general satisfaction is mentioned. Then the relationship between the diversity climate and general satisfaction in corporate level that may constitute the basis for the research has been established.

Diversity Climate

Diversity includes educational level, living, work experience, socio- economic background, income, religious beliefs, being disabled, working time in organisations, personality and marital status (Griffin ve Moorhead, 2010; Magoshi ve Chang, 2009; Lopez, 2008; Rijamampianina ve Carmichael, 2005; Williams ve O'Reilly, 1998). Esty, Griffin and Hirsh (1995) also describes the diversity as a situation arising from the concepts among people like age, class, ethnic origin, gender, physical and mental ability, race. Diversity covers gender, age, language, ethnicity, cultural background, religious belief and family responsibilities. Moreover, diversity also refers to the other ways in which people are different, such as educational level, life experience, work experience, socio-economic background, personality

and marital status. (Guidelines On Workplace Diversity, 2001). Also, diversity is the combination of all the characteristics that make us who we are, including nationality, race, culture, ethnic background, gender, age, religion, native language, physical ability, sexual orientation, education, and profession as a more inclusive statement (Diversity Annual Report, 2000).

Diversity climate is based on the perceptions of the organization for procedures, practices and policies related with diversity (Pugh, Dietz, Brief and Wiley, 2008). Diversity climate can be also defined as the component of the belief about diversities, and behavioral climate that includes how different races and ethnic groups interact in an environment (Hurtado, Milem, Clayton-Pedersen and Allen, 1999). Hyde and Hopkins (2004) indicate that the diversity climate of an organization consists of both the member heterogeneity level in the organization and the efforts to support and sustain a conducive environment that will maximize the benefits of this heterogeneity. Kaplan, Wiley and Maertz (2011) also studied diversity climate as a part of the organizational life and its perceptions working towards the value of individual differences. Diversity climate includes the values and beliefs of the minorities (Kyrillidou, 2009). Chin (2009) stated that the diversity climate of the organization includes the employee perceptions that occur in a variety of situations such as mistreatment and discrimination in the workplace (as cited in Goyal and Shrivastava, 2013: 55). Diversity climate can be also seen as individuals' perceptions that the individual and cultural diversities should be welcomed and embraced with respect and diversities should be valued (Ergül, Kurtulmuş and Karabıyık, 2014).

Garcia and Hoelscher (2010) reviewed the literature and found that four divergent themes widely acknowledged in their definition of diversity climate, these include: a) perception of degree of between-group conflict and acceptance of others, b) level of institutional commitment to diversity (e.g., promotion of personal and emotional safety, promotion of increased demographic representation of individuals from minority populations), c) fairness (e.g., acculturation processes, lack of institutional bias) and d) a generalized atmosphere of respect (e.g., personal attitudes and reduction of prejudices) (as cited in Goyal ve Shrivastava, 2013).

From the aspect of schools and universities, it can be said that diversity climate is based on the perceptions of both students and officials. Student diversity also can effect university campus just as employee diversity effects workplace environment. It is possible to say that the definition of diversity climate can be widen partially in the researches about diversity climate in universities. Therefore, it is thought a more suitable statement that diversity climate is described as perceptions of officials and students about effort made for promoting that the diversity is welcomed and embraced in a school where the diversity is supported, waited and rewarded (Sheau-yuen Yeo, 2006). The diversity climate in campuses includes the perceptions of, actual experiences with, and the quality of interactions between individuals and groups on campuses (Paredes-Collins, 2014). In universities/campuses, diversity climate includes the students' perceptions shaped with administrative practises, policies and procedures about diversity like gender, race, worldview, religion, lifestyle, experiences.

General Satisfaction

Satisfaction, used in the meaning of compliance, the feeling of filled with joy and exult in dictionaries (<http://www.tdk.gov.tr>), can be conceptualized as positive experiences of individuals about their values in the related field. (Sheau-yuen Yeo, 2006). Likewise, satisfaction can be considered as a function, too, associated with the perceived performance and expectation level (Abu Hasan, Ilias, Abd Rahman, Abd Razak, 2008). Student satisfaction is accepted as students' short term attitudes which are generally arised from evaluation of students' educational experiences (Elliott ve Healy, 2001). Student satisfaction is shaped by repeated experiences in a continuous manner in campus. (Elliott ve Shin, 2002).

The Relationship Between Diversity Climate And General Satisfaction

Researces on diversity climate suggest that diversity climate shows a strong relationship with both individual and organizational outcomes. For example, it is understood that there is relationship between diversity climate and commitment (McKay vd., 2007; Gonzalez ve DeNisi, 2009; Buttner, Lowe ve Billings-Harris, 2010; Poralan ve Solomon, 2013) customer satisfaction (McKay, Avery, Liao ve Morris, 2011; Goyal ve Shrivastava, 2013), job satisfaction (Madera, Dawson ve Neal, 2013; Hankins, 2005) release intention (Goyal ve Shrivastava, 2013), organizational identity (Gonzalez ve DeNisi, 2009), retention (Kaplan, Wiley ve Maertz, 2011; Price, Gözü, Kern, Powe, Wand, Golden ve Cooper, 2005),perceived organizational support (Hankins, 2005), organizational performance (Allen, Dawson, Wheatley ve White, 2006). In limited researches conducted in universities and educational institutions similar results are found. Researches (Sheau-yuen Yeo, 2006; Paredes-Collins, 2014) reveal that there is a relationship between the perceived diversity climate and the students' intentions to leave the school, their satisfaction for diversity and their psychological developments.

Taking part in the related literature, when the employees working at business organizations examined as well as the researches conducted on students in educational institutions, it is seen that the diversity climate is associated with a variety of output. In line with the scope of the diversity climate, it can be seen as a naturel condition that the perceived diversity climate is associated with different outcomes in both individual and organizational level. Hence, it is expected that there would be a positive relationship between the perceived diversity climate and overall satisfaction of students, and also the diversity climate would effect the overall satisfaction of students positively. Indeed, it is clear that it is impossible to mention maltreatment and discremination in orginazitions having strong diversity climate (Chin, 2009: as cited in Goyal ve Shrivastava, 2013). The settings in which there aren't maltreatment, degradation, exclusion and othering are important for that the individuals feel relaxed themselves. In this respect, that general satisfaction of individuals whose diversity is respected and who aren't being excluded is good can expected.

In accordance with mentioned literature, it is thought that percieved diversity climate effect the general satisfaction of students. In order to test this effect, two hypotheses have been developed, these are;

H₁: Percieved diversity climate affects the general satisfaction of students significantly and positively,

H₂: Percieved diversity climate explains the general satisfaction of students significantly.

Method

Research Model

The research has been performed in relational survey model. Relational survey model is a research model aiming to determine the existence and degree of change between two or more variables (Karasar, 2009: 81).

Working Group

Working group consisted of 273 student having education in Ziya Gökalp Faculty of Education and Faculty of Theology in Dicle University. Structural equation models is based on significance of differences in covariance matrix and tests sensitive to number of participants. Because of this, while structural equation is being set up, the number of participants must be over 200 (Bayram, 2010).

That working group ranged %37,4 male, %62,6 female according to gender; %,4 first grade, %2,6 second grade, %6,6 third grade, %83,2 fourth grade and %6,2 fifth grade according to level of grade; %4,8 Mediterranean Sea, %,7 Black Sea, %14,7 Aegean, %67,4 Southeast Anatolia, %8,4 Eastern Anatolia, %2,2 Central Anatolia ve %1,5 Marmara according to place of birth / geograpic region was observed.

Data Collection Instruments

Diversity Climate Scale: The scale developed by Ergül, Kurtulmuş ve Karabıyık (2014) aims to measure perceptions of students regarding to diversity climate in universities. The scale has a single-factor structure. The Cronbach Alpha coefficient consistence value of the scale is .89. In this research, the Cronbach Alpha coefficient consistence value of diversity climate scale has been found as .94. The scale involves 13 items being ranged from 1 (Strongly disagree) to 5(Strongly agree). The item, ‘Behave all students fairly taking diversities into consideration.’ can be shown as an example. In this resarch Confirmatory Factor Analysis (C.F.A.) has been done and that goodness of fit indexes are in the range of standard value ($\chi^2=19,161$; $df= 7$; $\chi^2/df= 2,73$; $RMSA=,08$; $AGFI = ,93$; $GFI= 97$; $CFI= 99$) has been observed.

General Satisfaction Scale: The scale developed by Sheau-yuen Yeo (2006) aims to measure the students’ satisfaction from the school in which they are having education at present. General satisfaction scale consists of a single-factor structure. The Cronbach Alpha coefficient consistence value of the scale is .91. In this research, the Cronbach Alpha coefficient consistence value has been found as .94. The scale has been designed as likert type with six items aiming to measure general satisfaction from school. The item, ‘I am happy for being student in this university.’ can be shown as an example. In this resarch C.F.A. has been done and that goodness of fit indexes are in the range of standard value ($\chi^2=176,340$;

df= 64; $\chi^2/df= 2,75$; $p=, 000$; $RMSA=,08$; $AGFI = ,87$; $GFI= 91$; $CFI= 95$) has been come out.

Data Analysis

Before analysis, normality distribution of data has been examined. In normality distribution of data, beside skewness (S) and kurtosis (K) values, arithmetic mean (\bar{X}) and median values (M) have been taken into consideration. Accordingly, that scores of diversity climate ($\bar{X}=2,87$; $M= 2,69$; $S= ,37$; $K= -,74$) and general satisfaction ($\bar{X}=2,32$; $M= 2,33$; $s= ,34$; $K= -,76$) scales don't show a considerable deviance from normal values can be said. Because that coefficient of skewness and kurtosis has remained in the range of ± 2 and median values are close each other, the scores are commented as not showing a considerable deviance from normal values (Ak, 2008; Bayram, 2013).

The data have been analysed with structural equation modeling. AMOS 20 packet programme has been used for analysis of data. In Model Goodness of Fit's assesment, chi-square / degree of freedom ($\chi^2 /sd= CMIN/DF$), significance level (p), Root Mean Square Error of Approximation (RMSEA), Goodness of Fit Index (GFI), Adjusted Goodness of Fit Index (AGFI), Comparative Fit Index (CFI), Normed Fit Index (NFI) have been considered. Used value ranges related to model are in Table 1.

Table 1: Standart Fit Value Ranges

Fit values	Acceptable fit	good fit
RMSEA	$.05 < RMSEA \leq .08$	$0 \leq RMSEA \leq .05$
GFI	$.85 \leq NFI < .89$	$.90 \leq NFI \leq 1.00$
CFI	$.95 \leq CFI < .97$	$.97 \leq CFI \leq 1.00$
NFI	$.90 \leq NFI < .94$	$.94 \leq NFI \leq 1.00$
AGFI	$85 \leq AGFI < .90$	$90 \leq AGFI \leq 1.00$
χ^2/df	$3 < \chi^2/df \leq 5$	$0 \leq \chi^2/df \leq 3$

Reference: Meydan ve Şeşen (2011).

Findings

In this research, a model has been developed in order to test the effect of perceived diversity climate on general satisfaction of students from university. The model has been developed in accordance with research's hypotheses. That developed structural equation model's fit values ($\chi^2=330,926$; $df= 149$; $p=,000$; $\chi^2/df=2,22$; $RMSEA=,06$; $CFI=,95$; $AGFI=,85$) are in the range of normal fit value and acceptable is understood. These results show that the tested model is significant. The model developed for testing the effect of perceived diversity climate on general satisfaction of students from university is in Figure 1.

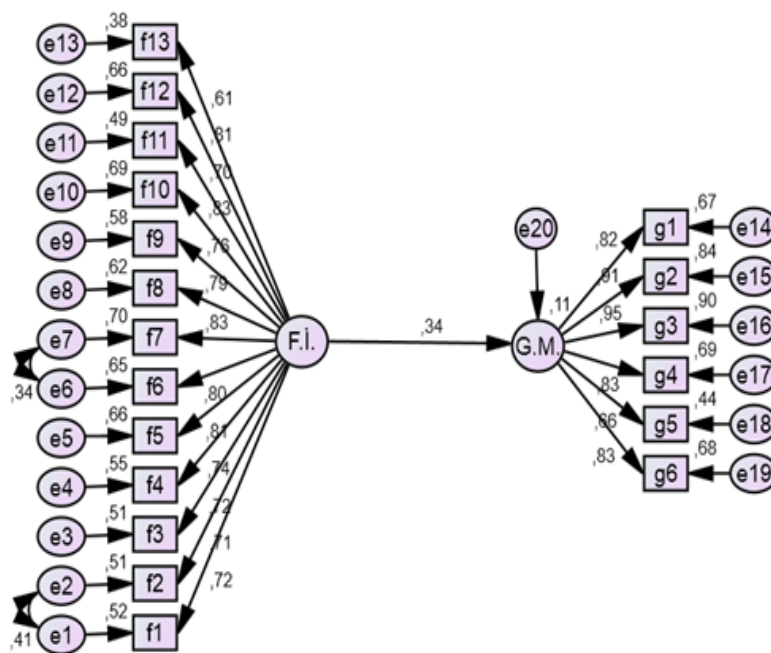

Figure 1: Structural Equation Modeling

When Figure 1 is analyzed, it is understood that perceived diversity climate affects the general satisfaction of students significantly and positively ($\beta=.34$ $p<.00$). This finding shows that the hypothesis, “Perceived diversity climate affects the general satisfaction of students significantly and positively” in H₁ hypothesis is confirmed. On the other hand, it is seen that perceived diversity climate explains %11 of students’ general satisfaction. This finding also shows that the hypothesis, “Perceived diversity climate explains the general satisfaction of students significantly” in H₂ hypothesis is verified.

Conclusion and Discussion

The results of this research prove that there is a significant and positive oriented relationship between perceived diversity climate and general satisfaction of students and perceived diversity climate explains the general satisfaction of students significantly. The results show that the hypotheses of research have been verified. That the results of this research and other

studies related to diversity management in literature support each other is seen. McKay et al. (2011) has reached the result of that perceived diversity climate and general customer satisfaction are related to each other. Yet, Goyal and Shrivastava (2013) have also set that there is a positive oriented relationship between diversity climate and employee satisfaction. Elliot and Healy (2001) has also proved that campus climate affects the satisfaction of students potently.

That perceived diversity climate explains the general satisfaction of students significantly enables us to make some inferences. It can be said that universities aiming to increase general satisfaction of students should considerate student diversity is important. If universities see the diversity natural and welcome it, they can contribute to increase general satisfaction of students. Because, a strong diversity climate which will come into existence in universities will make a significant contribution to general satisfaction of students.

From another viewpoint, universities can minimize the problems arising from weak diversity climate by valuing student diversity. Hurtado, Milem, Clayton-Pedersen and Allen (1999) have also expressed an opinion in this direction and emphasized that universities should make an effort for enhancing diversity climate by foreseeing the wide aspects of problems which weak diversity climate will cause. That universities should present institutional policies and practises in order to increase perceptions for general climate which universities welcome and accept (Sheau-yuen Yeo, 2006) can be given example as practises which improve diversity climate. Besides, to develop diversity climate in universities, they should consider these principles: a) affirm the goal of achieving a campus climate that supports racial and cultural diversity as an institutional priority b) implement a detailed and ongoing evaluation program to monitor the effectiveness of and build support for programmatic activities aimed at improving the campus climate c) create collaborative and cooperative environment where students' learning and interaction among diverse groups can be enhanced d) initiative curricular and cocurricular activities that increase dialogue and build bridges across different communities (Hurtado, Milem, Clayton-Pedersen ve Allen, 1999).

Actually, universities shouldn't constitute strong diversity climate by thinking only student satisfaction since university and schools act as model for society and students (Lumby ve Coleman, 2007). Educational institutions in which diversity is adopted, approved and accepted as richness effect positively at the point of perceiving diversity both immediate environment in the short term and remote environment in the long term (Kurtulmuş, 2014). Therefore, universities can acquire positive gains from different perspectives by having a strong diversity climate in which diversity is welcomed and embraced in itself. It is possible to say that the mentioned state will be worth studying in searches about diversity climate in the future.

References

Abu Hasan, H. F., Ilias, A., Abd Rahman, R. and Abd Razak, M. Z. (2008). Service Quality and Student Satisfaction: A Case Study at Private Higher Education Institutions. *International Business Research*. 1(3), July

Ak, B. (2008). Güvenirlik Analizi. SPSS Uygulamalı Çok Değişkenli İstatistik Teknikleri (Editor: Şeref Kalaycı). Ankara: Asil Publishing.

Allen, R. S., Dawson, G., Wheatley, K., and White, C. S. (2008). Perceived diversity and organizational performance. *Employee Relations*, 30(1), 20-33.

Barutçugil, İ. (2007). Kültürler Arası Farklılıkların Yönetimi. İstanbul: Kariyer Publishing.

Bayram, N. (2009). Sosyal Bilimlerde SPSS ile Veri Analizi. Ezgi Bookstore. Bursa.

Buttner, E. H., Lowe, K. B., and Billings-Harris, L. (2010) "Diversity climate impact on employee of color outcomes: does justice matter?" *Career Development International*.15 (3), 239-258. DOI 10.1108/13620431011053721

CIPD Change Agenda. (2005). Managing diversity: linking theory and practice to business performance. <http://www.cipd.co.uk/NR/rdonlyres/D4D2D91FC8A4FD2A814B80A55A60B87/0/mandivlink0405.pdf> (Date accessed: 05.03.2014)

Cox, T. H. And Blake, S. (1991). Managing cultural diversity: Implications for organizational competitiveness. *Academy of Management Executive*. 5(3).

Diversity Annual Report. (2000). <http://www.imf.org/external/np/div/2000/> (Date accessed: 13.01.2014).

Elliott, K. M. and Healy, M. A. (2001). Key Factors Influencing Student Satisfaction Related to Recruitment and Retention. *Journal of Marketing for Higher Education*. Vol. 10(4).

Elliott, K. M. ve Shin, D. (2002). Student Satisfaction: An alternative approach to assessing this important concept. *Journal of Higher Education Policy and Management*, 24(2), 197-209, DOI: 10.1080/1360080022000013518

Ergül, H.F., Kurtulmuş, M. and Karabıyık, H. (2014). Üniversitelerde Farklılık İklimi Ölçeği Geçerlik ve Güvenirlik Çalışması. *Electronic Journal of Education Sciences*, 3(6), 84-96

Esty, K., Griffin, R. and Hirsch, M. S. (1995). Workplace diversity: A Manager's guide to solving problems and turning diversity into a competitive advantage. [www. http://books.google.com](http://books.google.com) (Date accessed: 03.02.2014)

Gonzalez, J. A., and DeNisi, A. S. (2009). Cross-level effects of demography and diversity climate on organizational attachment and firm effectiveness. *Journal of Organizational Behavior*, 30, 31 – 40.

Goyal, S. and Shrivastava, S. (2013). Organizational Diversity Climate: Review of Models and Measurement. *Journal of Business Management & Social Sciences Research (JBM&SSR)* Volume 2, No.5, May 2013

Griffin, R. W. ve Moorhead, G. (2010). Organizational Behavior: Managing People And Organizations. Cengage Learning. South Western.

Guidelines On Workplace Diversity. (2001). <http://www.apsc.gov.au/publications-and-media/archived-publications/publications-ar>

chive/workplace-diversity-guidelines# (Date accessed: 13.01.2014).

Hankins, K. A. (2005). The Influence of Diversity Climate on Perceived Organizational Support and Job Satisfaction. PhD Thesis. Capella University.

Hom, W. (2002). Applying Customer Satisfaction Theory to Community College Planning of Student Services. IJournal. Retrieved January 7th 2004, from http://www.ijournal.us/issue_02/ij_issue02WillardHom_01.htm

Hubbard, E. E. (2004). The Manager's pocket guide to diversity management. Published By: Harward Press. 22 Amherst Road Amherst. U.S. And Canada.

Hurtado, S., Milem, J., Clayton-Pedersen, A. and Allen, W. (1999). Enacting Diverse Learning Environments: Improving the Climate for Racial/Ethnic Diversity in Higher Education. ASHE-ERIC Higher Education Report. 26(8).

http://www.tdk.gov.tr/index.php?option=com_bts&arama=kelime&guid=TDK.GTS.54dc7c21f17378.00945303

Hyde, C. and Hopkins, K. "Assessing the Diversity Climates in Human Service Agencies." *Journal of Ethnic & Cultural Diversity in Social Work*, vol. 13, no. 2, pp. 25-43, 2004.

Kaplan, D. M., Wiley, J.W. and Maertz, C.P. (2011). The Role Of Calculative Attachment In The Relationship Between Diversity Climate And Retention. *Human Resource Management, Human Resource Management*. 50(2).

Karasar, N. (1995). *Bilimsel Araştırma Yöntemi*. (19. Basım). Ankara: Alkim Publications.

Kevin M. Elliott & Margaret A. Healy (2001) Key Factors Influencing Student Satisfaction Related to Recruitment and Retention, *Journal of Marketing for Higher Education*, 10:4, 1-11, DOI: 10.1300/J050v10n04_01

Knouse, S. B. (2008). Issues In Diversity Management. (DEOMI-Report 08-04). Patrick Air Force Base, FL: Defense Equal Opportunity Management Institute.

Kurtulmuş, M. (2014). Farklılıkların Yönetiminin öğretmenlerin Örgütsel Bağlılıklarına ve Vatandaşlık Davranışlarına Etkisi. Yayınlanmamış Doktora Tezi. Dicle Üniversitesi. Ziya Gökalp Eğitim Fakültesi. Diyarbakır.

Kyrillidou, M., Lowry, C., Hanges, P., Aiken, J., and Justh K. (2009). ClimateQUAL™: Organizational Climate and Diversity Assessment. ACRL Fourteenth National Conference. March 12 15, 2009, Seattle, Washington.

Lopez, C.M. (2008). School management in multicultural contexts. *The International Journal of Leadership in Education*. 11(1).

Lumby, J. and Coleman, M. (2007). Introduction: Diversity, leadership and education http://www.sagepub.com/upm-data/14398_Lumby_Chapter_1.pdf (Date accessed: 10.04.2013)

- Madera, J. M., Dawson, M. ve Neal, J. A. (2013). Hotel managers' perceived diversity climate and job satisfaction: The mediating effects of role ambiguity and conflict. *International Journal of Hospitality Management*, 35, 28–34
- Magoshi, E. and Chang, E. (2009). Diversity management and the effects on employees' organizational commitment: Evidence from Japan and Korea. *Journal of World Business*. 44.
- Meydan, C. H. ve Şeşen, H. (2011). Yapısal Eşitlik Modellemesi AMOS uygulamaları. Ankara: Detay Publishing.
- McKay P. F, Avery D. R, Tonidandel S, Morris M. A, Hernandez M, Hebl M. R. (2007). Racial Differences in Employee Retention: Are Diversity Climate Perceptions The Key? *Personnel psychology*. 60.
- McKay, P. F., Avery, D. R., Liao, H., and Morris, M. A. (2011). Does diversity climate lead to customer satisfaction? It depends on the service climate and business unit demography. *Organization Science*, 22, 788 – 804.
- Morrison, M., Lumby, J. and Sood, K. (2006). Diversity and diversity management: Messages from recent research. *Educational Management Administration ve Leadership*. 34(3).
- Okat, B. (2010). Örgütlerde Farklılıkların Yönetimi ve Farklılık İklimine Kuramsal Bir Yaklaşım. Yayınlanmamış Yüksek Lisans Tezi. Dokuz Eylül Üniversitesi. Sosyal Bilimler Enstitüsü. İzmir.
- Palacio, A. B., Meneses, G. D. and Perez, P. J. P. (2002). The configuration of the university image and its relationship with the satisfaction of students. *Journal of Educational Administration*, 40(5), 486-505.
- Paredes-Collins, K. (2014). Campus Climate for Diversity as a Predictor of Spiritual Development at Christian Colleges, *Religion & Education*, 41:2, 171-193, DOI: 10.1080/15507394.2013.864206
- Poralan, P. S. and Solomon, J. Y. 2013. Diversity Climate and Affective Commitment of Teachers in Tertiary Schools. *International Peer Reviewed Journal*. 7. October doi: <http://dx.doi.org/10.7718/iamure.ijbm.v7i1.707>.
- Price, E. G., Gozu, A., Kern, D. E., Powe, N. R., Wand, G. S., Golden, S. and Cooper, L. A. 2005. The Role of Cultural Diversity Climate in Recruitment, Promotion, and Retention of Faculty in Academic Medicine. *J GEN INTERN MED*. 20:565–571. DOI: 10.1111/j.1525-1497.2005.0127.x
- Pugh, S.D., Dietz, J., Brief, A.P., and Wiley, J.W. (2008). Looking inside and out: The impact of employee and community demographic composition on organizational diversity climate. *Journal of Applied Psychology*, 93, 1422–1428.
- Rijamampianina, R. and Carmichael, T. (2005). General issues in management: A pragmatic and holistic approach to managing diversity. *Problems and Perspectives in Management*. 1.

Sheau-yuen Yeo, M. A. (2006). Measuring organizational climate for diversity: A construct validation approach. Unpublished Doctoral thesis. The Ohio State University.

Van Vuuren, H. J., Van Der Westhuizen, P. C. & Van Der Walt, J.L. (2012). The management of diversity in schools — A balancing act. *International Journal of Educational Development*. 32.

Williams, K. Y. and O'Reilly, C. A. (1998). Demography and diversity in organizations: A review of 40 years of research. *Research in Organizational Behavior*. 20.